

REV.	ECN NO.	LOCATIONS	DESCRIPTION	DATE	REVISER	APPD

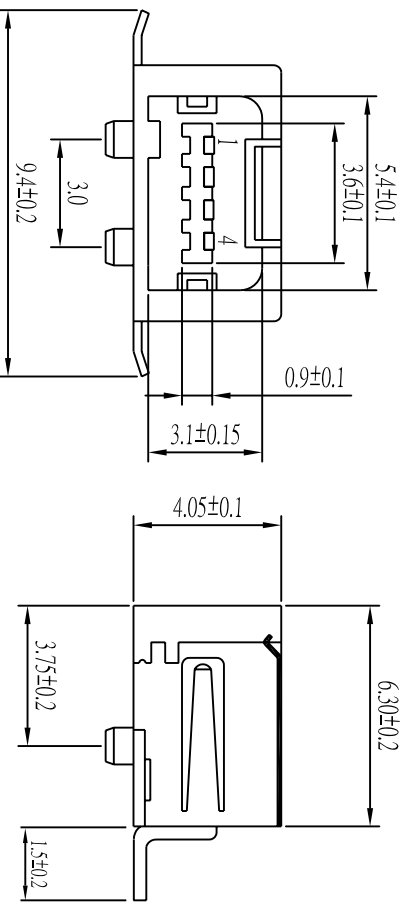
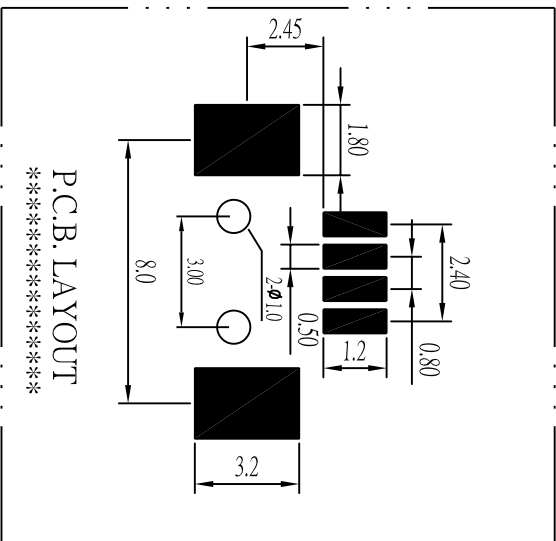
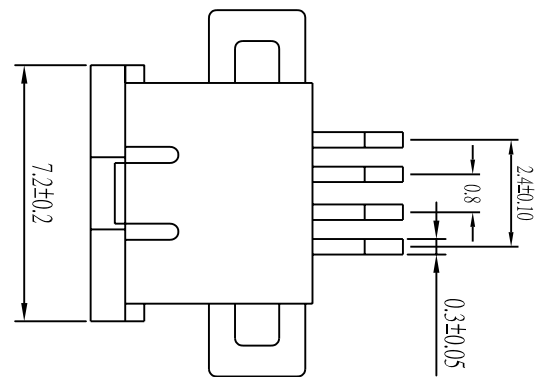

- Note:
- 1.Material:
- 1.1 Insulator: High temperature thermoplastic with g.f.UJ94V-0
 - 1.2 Contact: Copper alloy,t=0.25mm
 - 1.3 Shell: Spec.t=0.20mm
- 2.Specification:
- 2.1 Current rating: 1 A Max.
 - 2.2 Dielectric withstanding voltage: 750 V(ac) for 1 min.
 - 2.3 Contact resistance: 30 mΩ Max.
 - 2.4 Insulation resistance: 1000 MW Min.
 - 2.5 Total mating force: 2.5 Kgf Max.
 - 2.6 Total unmating force: 0.5 Kgf Min.
 - 2.7 Temperature range: -55°C~85°C

No.	Name	Qty	Part No.	Finish
8	Back-shell			
7	Front-shell			
6	Clip			No finish
5	Contact			
4	Contact			
3	Contact			Selective Au plated on mating area
2	Contact			
1	Housing			Black

PART NO:		MATERIAL:	
MODEL NO:		FINSH:	
UNIT: mm	SIZE:	COLOR:	
TOLERANCE UNSPECIFIED			
x	±0.3	DR:	
.xx	±0.20	CHK:	
.xxx	±0.100	APP:	
ANG.	±1°	f	
PART NAME:		DWG NO:	
MINIUSB-(HRS) TYPE(F) S.M.T		HC-006	
SCALE: 2:1		SHEET: 1 of 1	
REV: A0		REV: A0	